



All Kwik Goal products carry a **Lifetime Guarantee**. For help with guarantee issues, visit [kwikgoal.com](http://kwikgoal.com) and click on the **Lifetime Guarantee** logo or contact customer service at 1-800-531-4252.

ASSEMBLY INSTRUCTIONS FOR 9B315 BENCH WITH SHELF X 15 FOOT

**\*THIS MUST BE ASSEMBLED BY A MINIMUM OF TWO QUALIFIED PERSONS\*  
PERMANENT GROUND ANCHORS ARE RECOMMENDED FOR THIS SEATING.**

1. Unpack all parts and check for damage which may have occurred during shipping. If damage has occurred, notify trucking company immediately. Lay out all parts. Remove all cardboard or packaging immediately; wet or damp packaging may damage contents.
2. Read through entire instruction before beginning assembly and installation.

**NOTE: Components may be packaged in one or more additional boxes.**

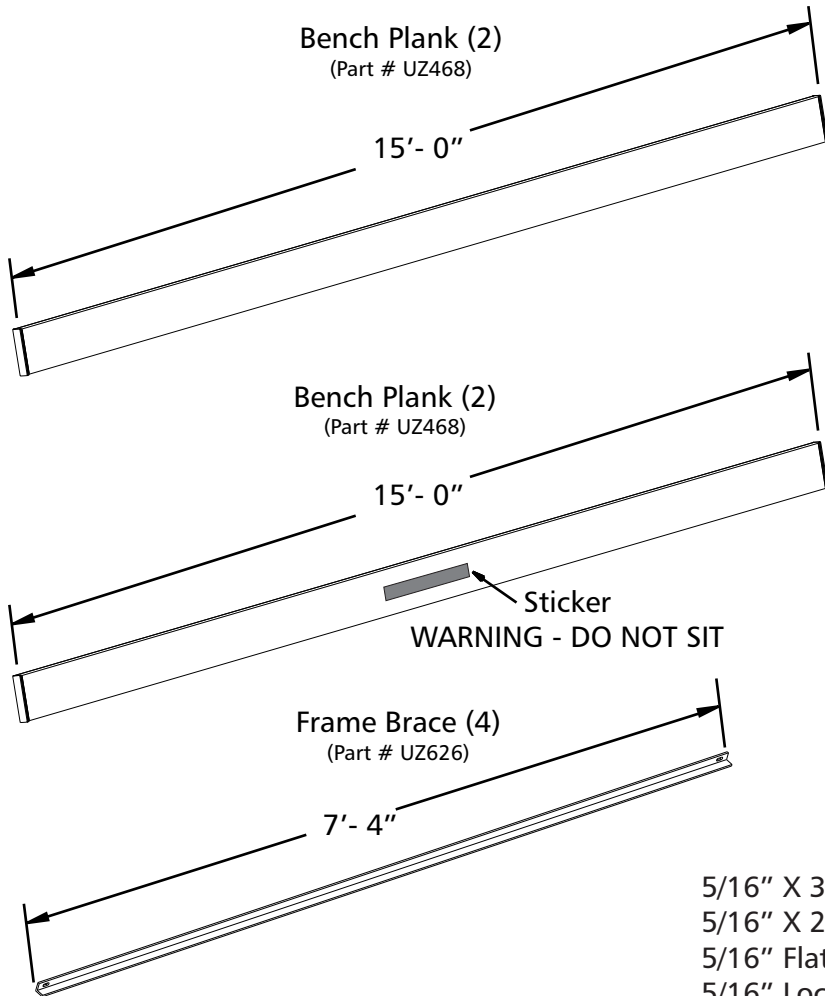

**Assembly Tools**

1/2" Wrench or 1/2" Socket with Ratchet

**Bench Frame (3)**  
(Part # UZ1237)

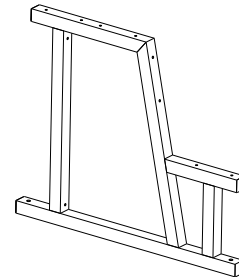

**Bench Hold Down (24)**  
(Part # UZ475)

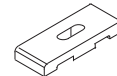

**Hardware**

- 5/16" X 3" Carriage Bolt (KG Part # TZ172) (26)
- 5/16" X 2 3/4" Carriage Bolt (KG Part # TZ191) (4)
- 5/16" Flat Washer (KG Part # TZ4) (30)
- 5/16" Lock Nut (KG Part # TZ5) (30)

140 Pacific Drive Quakertown, PA 18951  
(P) 215- 536-2200 / (P) 800-531-4252 / (F) 215-536-4309 / (F) 800-778-8869  
Visit our website @ [kwikgoal.com](http://kwikgoal.com)

2. Attach frame braces to bench frame as shown.  
**(Note: Do NOT tighten bolts until all frame braces and bench frames are connected.)**

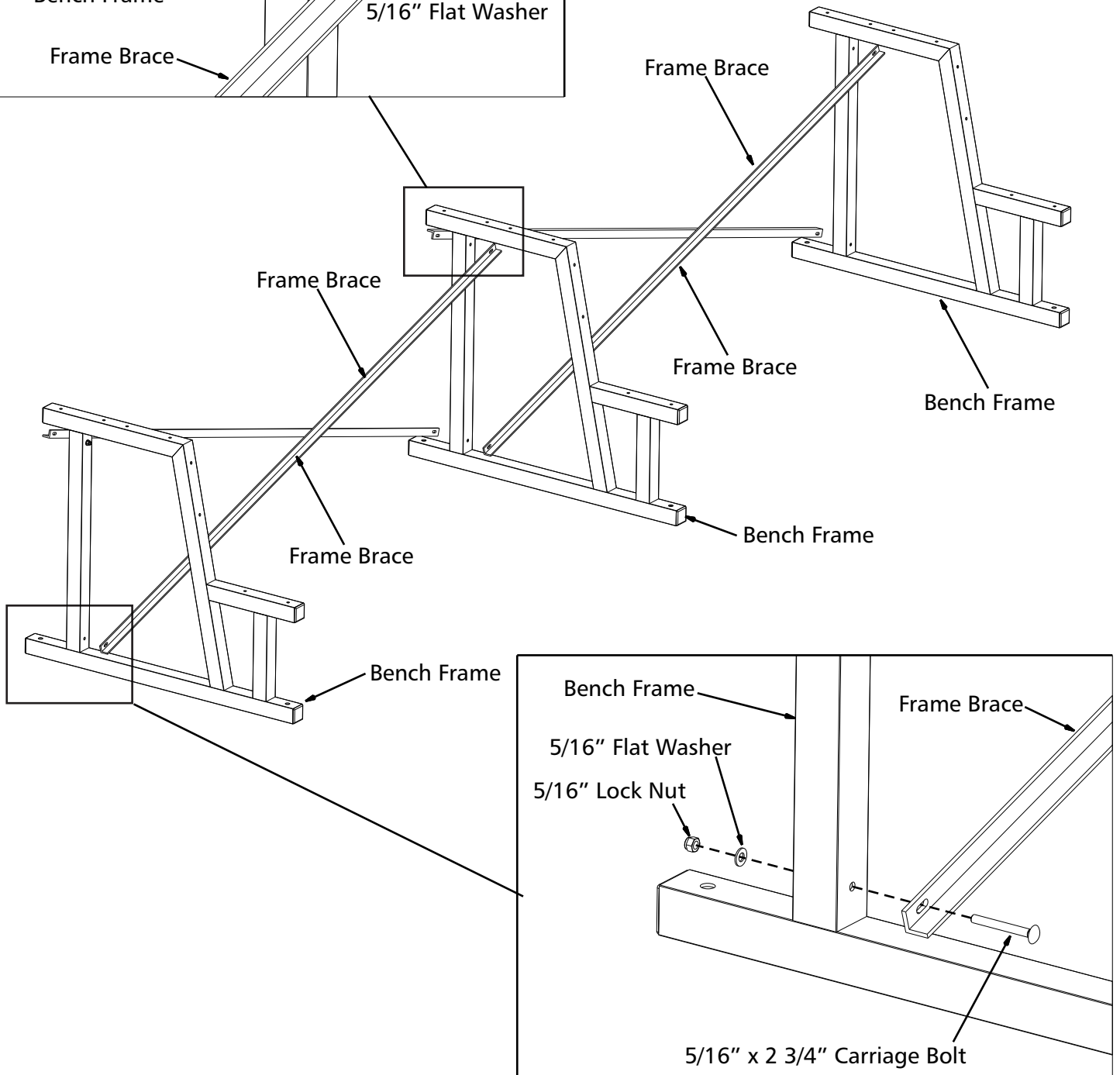
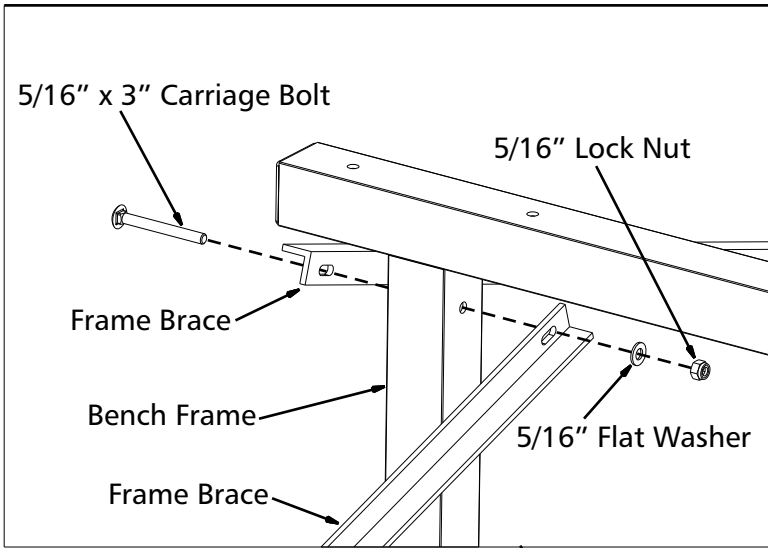

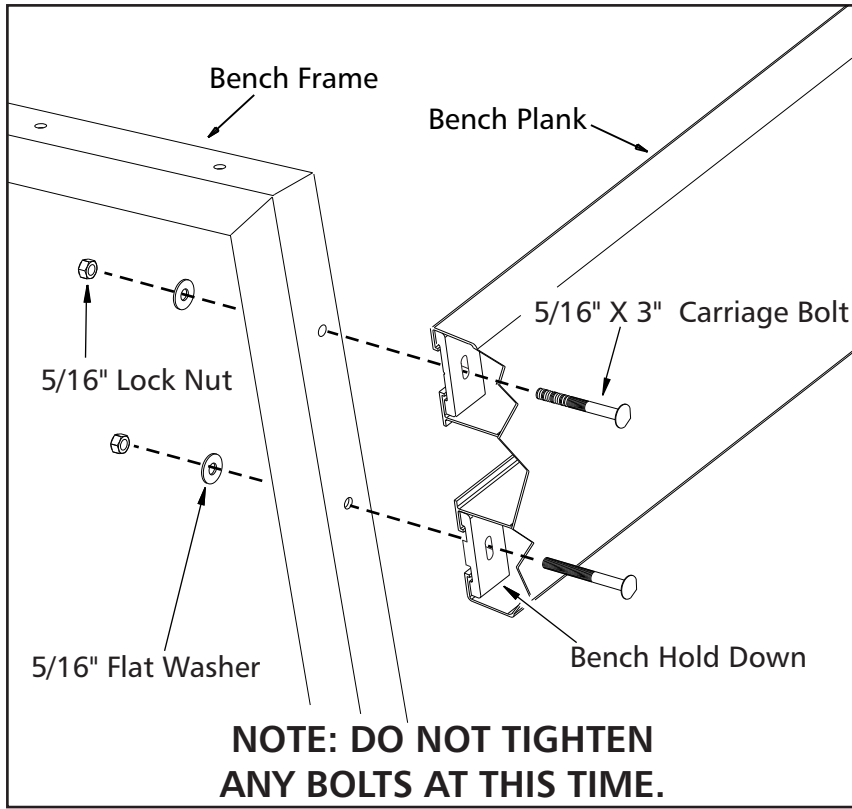

- Attach the first bench plank to all bench frames at locations shown.  
Note: Use bench plank that does NOT have sticker (WARNING - DO NOT SIT).  
**(Do NOT tighten bolts at this time.)**

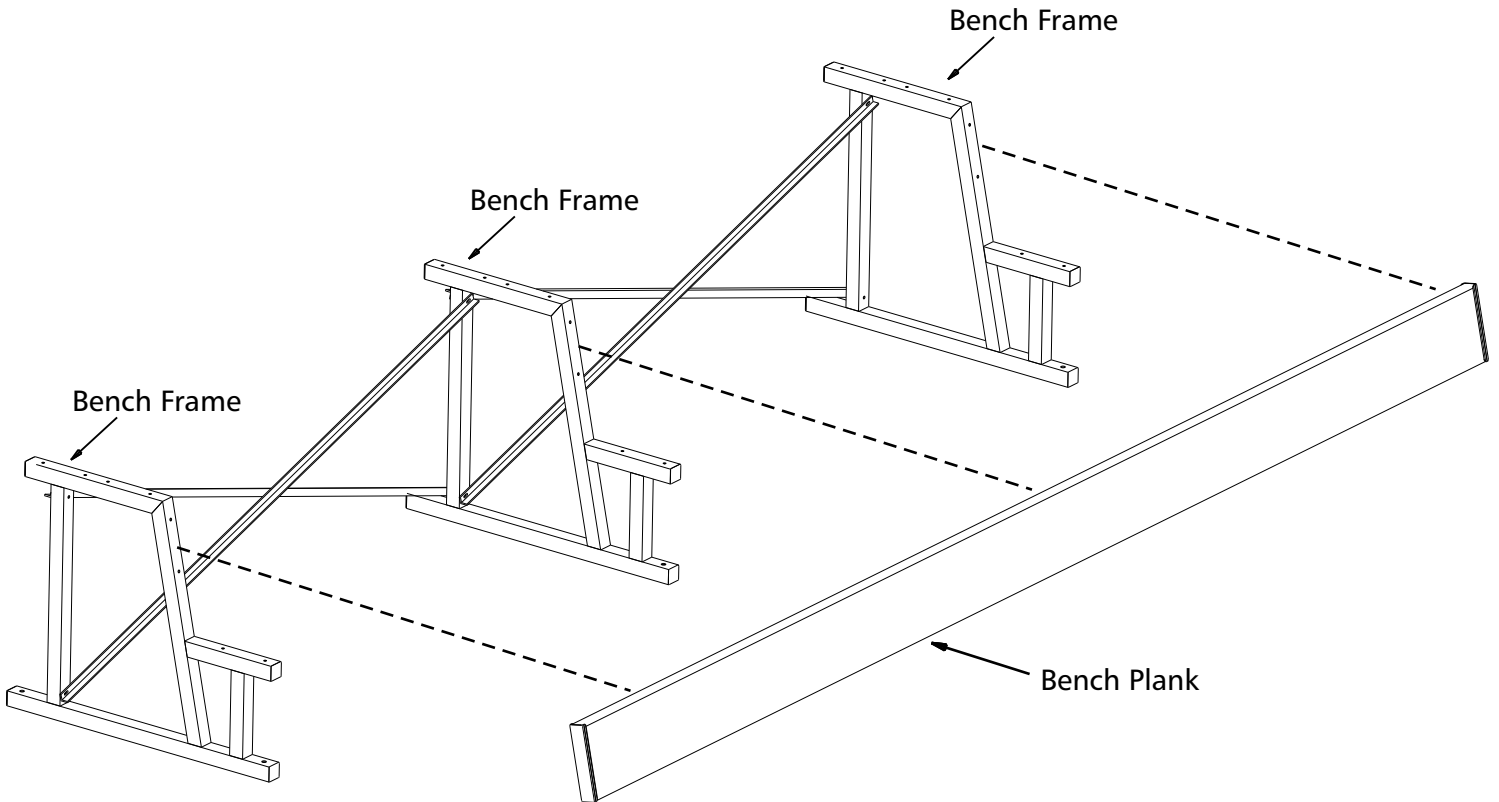

**NOTE: DO NOT TIGHTEN ANY BOLTS AT THIS TIME.**

5/16" X 3" Carriage Bolt

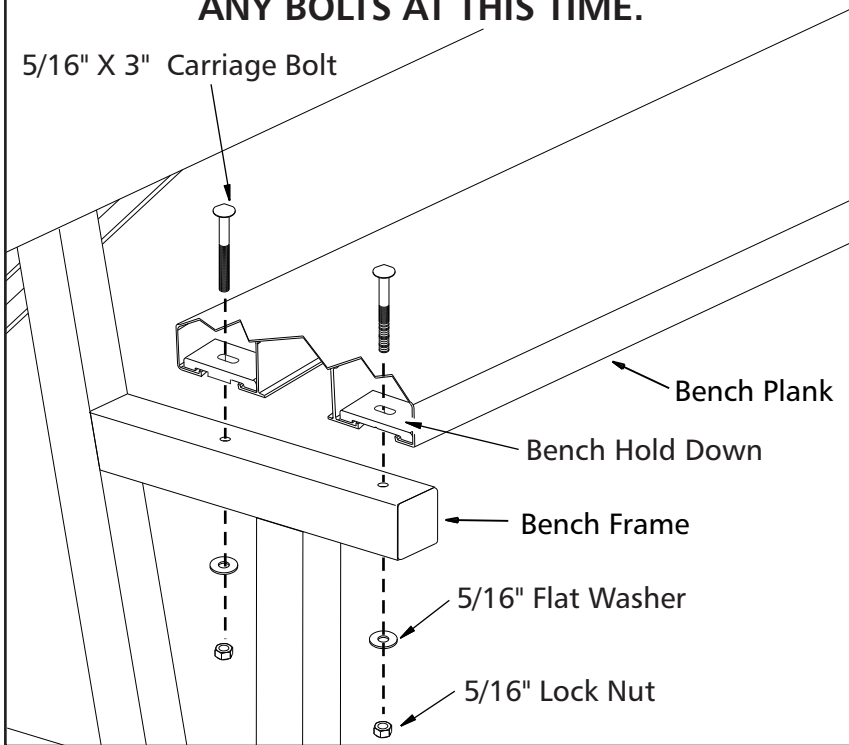

4. Attach the remaining bench planks to all bench frames at locations shown. Note the location of bench planks with sticker (WARNING - DO NOT SIT). Before tightening bolts, square up bench planks with bench frames be sure shelf bench planks are against each other. Tighten all bolts at this time.

